

Ref. 380614

Kabelanschluss-Set / Kit de câble de raccordement / Cable Connector Kit / Snoer aansluitset / Kit de cables de conexión

Lieferumfang:
Contenu de la livraison:
Included in delivery:
Pakketinhoud:
Volumen de entrega:

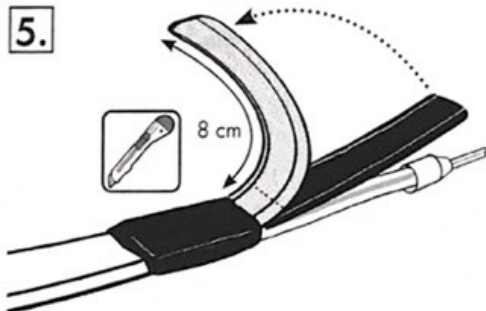

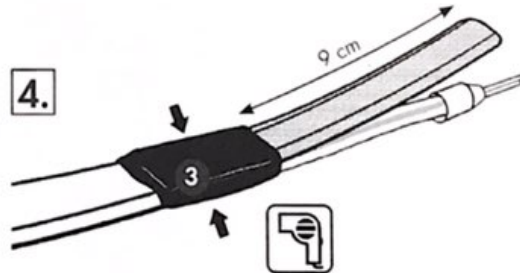
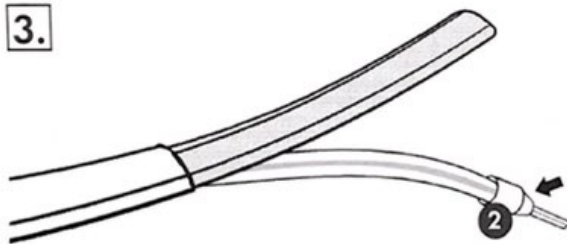
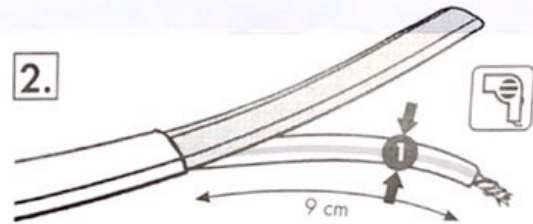
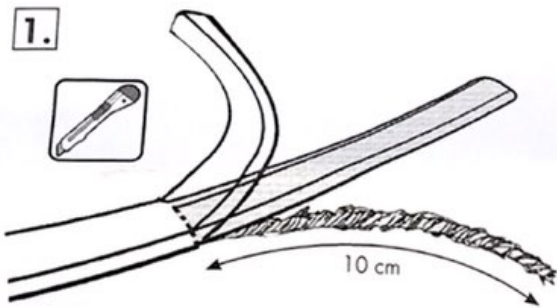
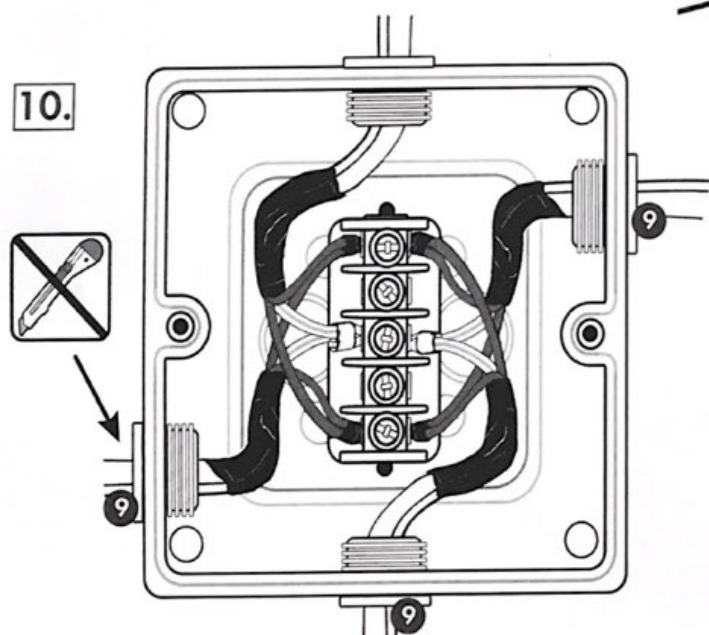
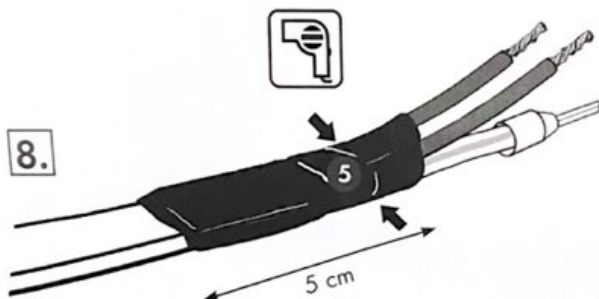
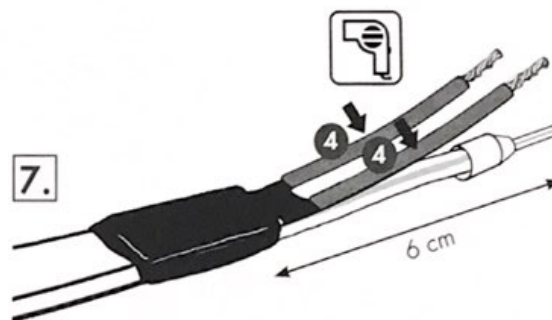
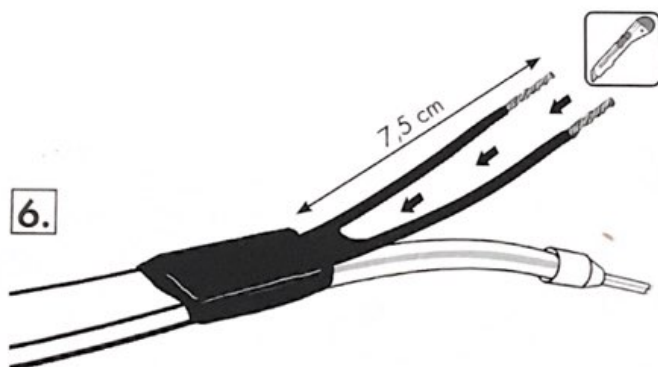

Installation nur von einem Fachmann vornehmen lassen!

The installation should be effected only by qualified appointed personnel.

L'installation doit être faite uniquement par un professionnel!

De installatie moet uitsluitend door een erkent installateur uitgevoerd worden!

¡Instalación por persona cualificada!

Ref. 380611

Netzanschluss-Set

Kit alimentation secteur / Mains Connection Kit / Netaansluitingsset / Kit de alimentación de red

Aufbauzeit / Temps de montage /
 Installation time / montagemtijd /
 Tiempo de montaje: ≈ 15 Min.

Aufbau mit einer Person
Montage par 1 personne
 Mounting instruction for assembling
 with 1 person
 Met een persoon opbouwen
 Montaje por 1 persona



Schraubendreher / *Toumevis* / Screwdriver /
 Schroevendraaier / *Destornillador*
 Seitenschneider / *Pince coupante* / Cutting
 pliers / *Zijknijtang* / *Alicates de corte*
 Kabel Crimpzange / *Pince à sertir* / Cable
 crimper / *Krimptang* / *Tenaza de crimpado*
 Cuttermesser / *Cutter* / Box cutter / *Snijmes*
 met Glijstuk / *Cúter*
 Heißluftföhn / *Décapeur thermique* / Hot
 air gun / *Heteluchtblazer* / *Decapador*
térmico

Lieferumfang / Contenu de la livraison / Included in delivery / Pakketinhoud / Volumen de entrega

	Bezeichnung / Description / Description / Beschrijving / Descripción
1	1x Schrumpfschlauch gelb/grün 2,4 mm, L = 100 mm / Gaine thermorétractable jaune/verte 2,4 mm, L = 100 mm / Shrinking hose 2.4 mm, yellow/green, L = 100 mm / Krimpkous geel/groen 2,4 mm, L = 100 mm / Tubo termoretráctil amarillo/verde 2.4 mm, L = 100 mm
2	1x Aderendhülse gelb / Embout de fil jaune / Wire end ferrule, yellow / Adereindhuls geel / Terminal de cable amarillo
3	1x Schrumpfschlauch schwarz, 9,5 mm, kurz, L = 30 mm / Gaine thermorétractable noire 9,5 mm, courte, L = 30 mm / Shrinking hose, 9.5 mm, black, short, L = 30 mm / Krimpkous zwart 9,5 mm, kort, L = 30mm / Tubo termoretráctil negro, 9.5 mm, corto, L = 30 mm
4	2x Schrumpfschlauch schwarz, 4,8 mm, L = 60 mm / Gaine thermorétractable noire 4,8 mm, L = 60 mm / Shrinking hose, 4.8 mm, black, L = 60 mm / Krimpkous zwart 4,8 mm, L = 60mm / Tubo termoretráctil negro, 4.8 mm, L = 60 mm
5	1x Schrumpfschlauch schwarz, 9,5 mm, lang, L = 50 mm / Gaine thermorétractable noire 9,5 mm, longue, L = 50 mm / Shrinking hose, 9.5 mm, black, long, L = 50 mm / Krimpkous zwart 9,5 mm, lang, L = 50 mm / Tubo termoretráctil negro, 9.5 mm, largo, L = 50 mm
6	2x Aderendhülse rot / Embout de fil rouge / Wire end ferrule red / Adereindhuls rood / Terminal de cable rojo
7	1x Abzweigkasten mit Anschlussklemme / Boîte de jonction avec borne de connexion / Junction box with connection terminal / Kabelladoos met kroonsteen / Caja de conexiones con borne de conexión
8	1x Anschlussklemme für Abzweigkasten / Borne de raccordement pour boîte de jonction / Connection terminal for junction box / Kroonsteen voor Kabelladoos / Borne de conexión para caja de conexiones
9	1x Kabelverschraubung / Presse-étoupe pour câble / Cable gland / Kabelschroefverbinding / Prensaestopas para cable

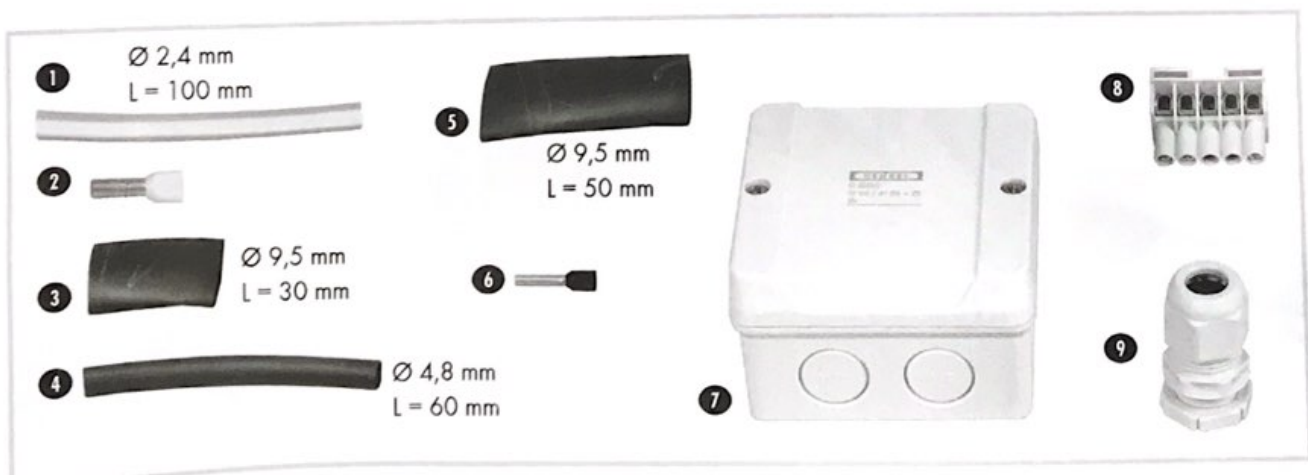

1.

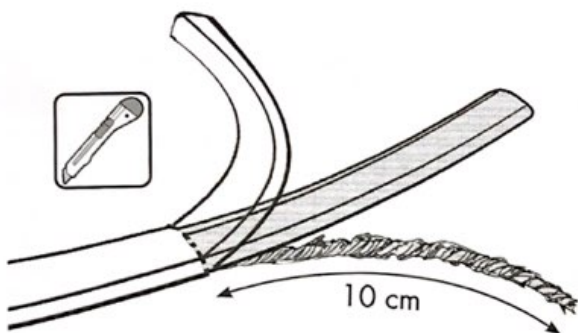

2.

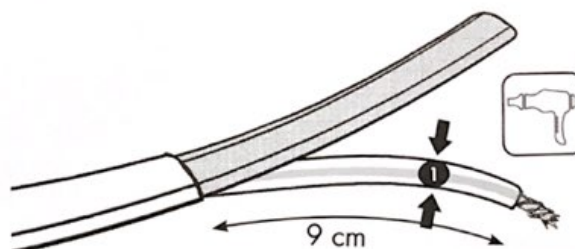

3.

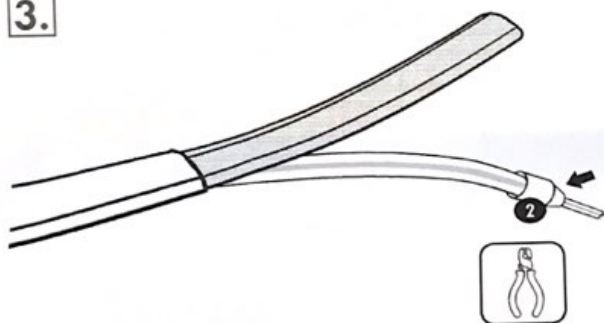

4.

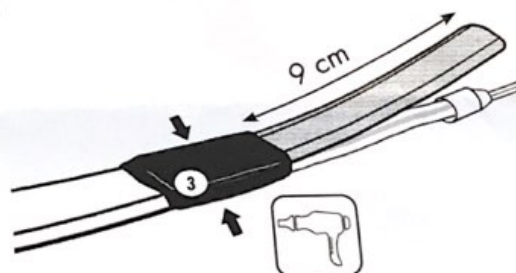

5.

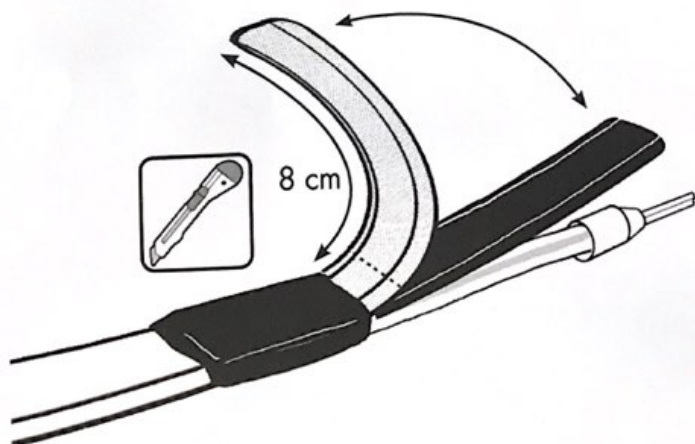

6.

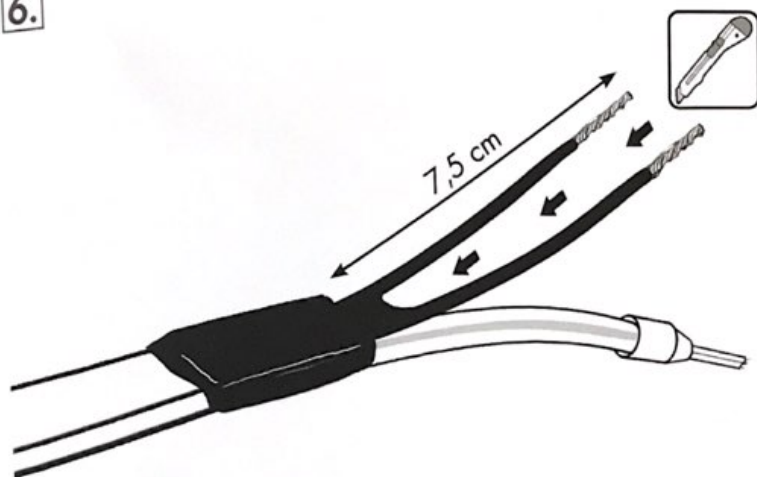

7.

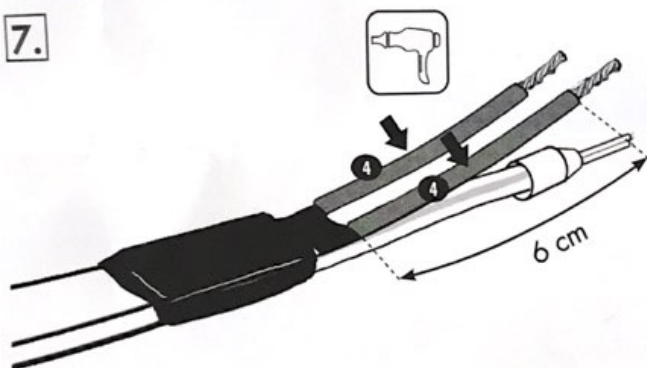

8.

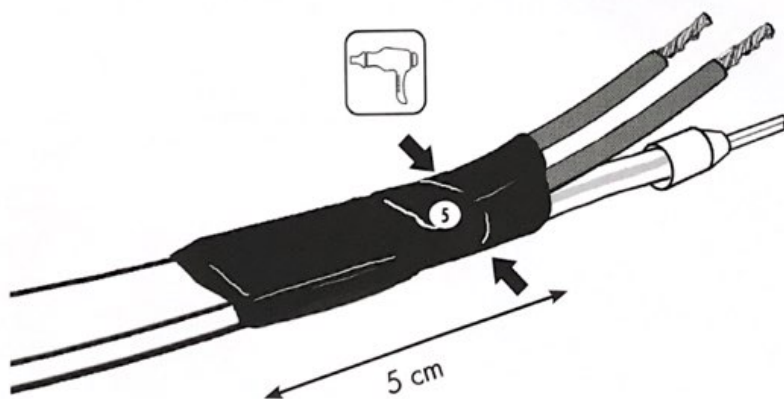

9.

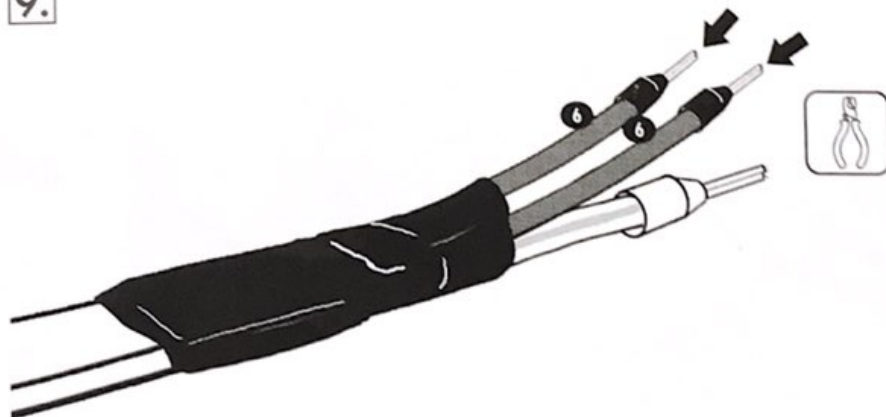

10.

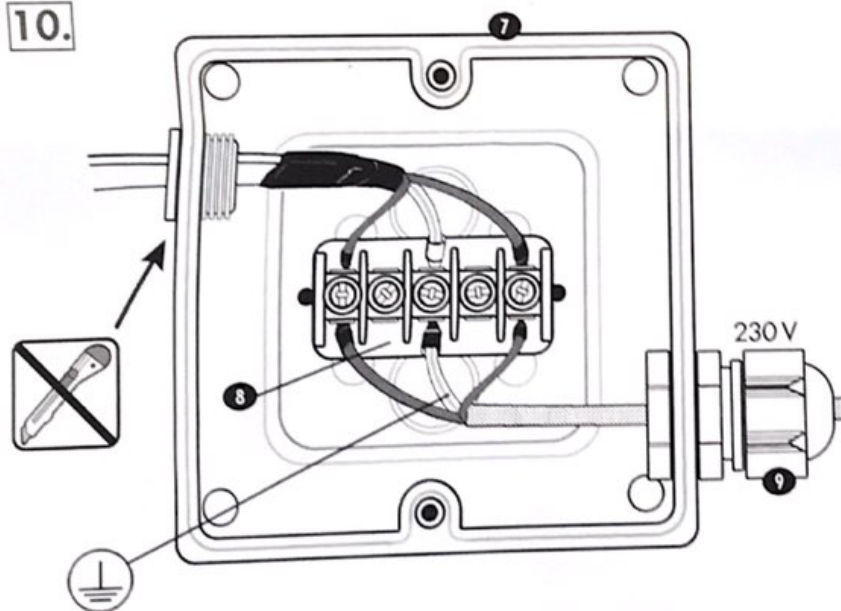

Installation nur von einem Fachmann vornehmen lassen!

L'installation doit être faite uniquement par un professionnel!

Installation and service work may only be carried out by authorized specialist personnel

De installatie moet uitsluitend door een erkent installateur uitgevoerd worden!

¡Instalación por persona cualificada!

Ref. 380612

End-Set / Kit de fin / Termination Kit / Eindset / Kit de terminación

Lieferumfang:
Contenu de la livraison:
Included in delivery:
Pakketinhoud:
Volumen de entrega:

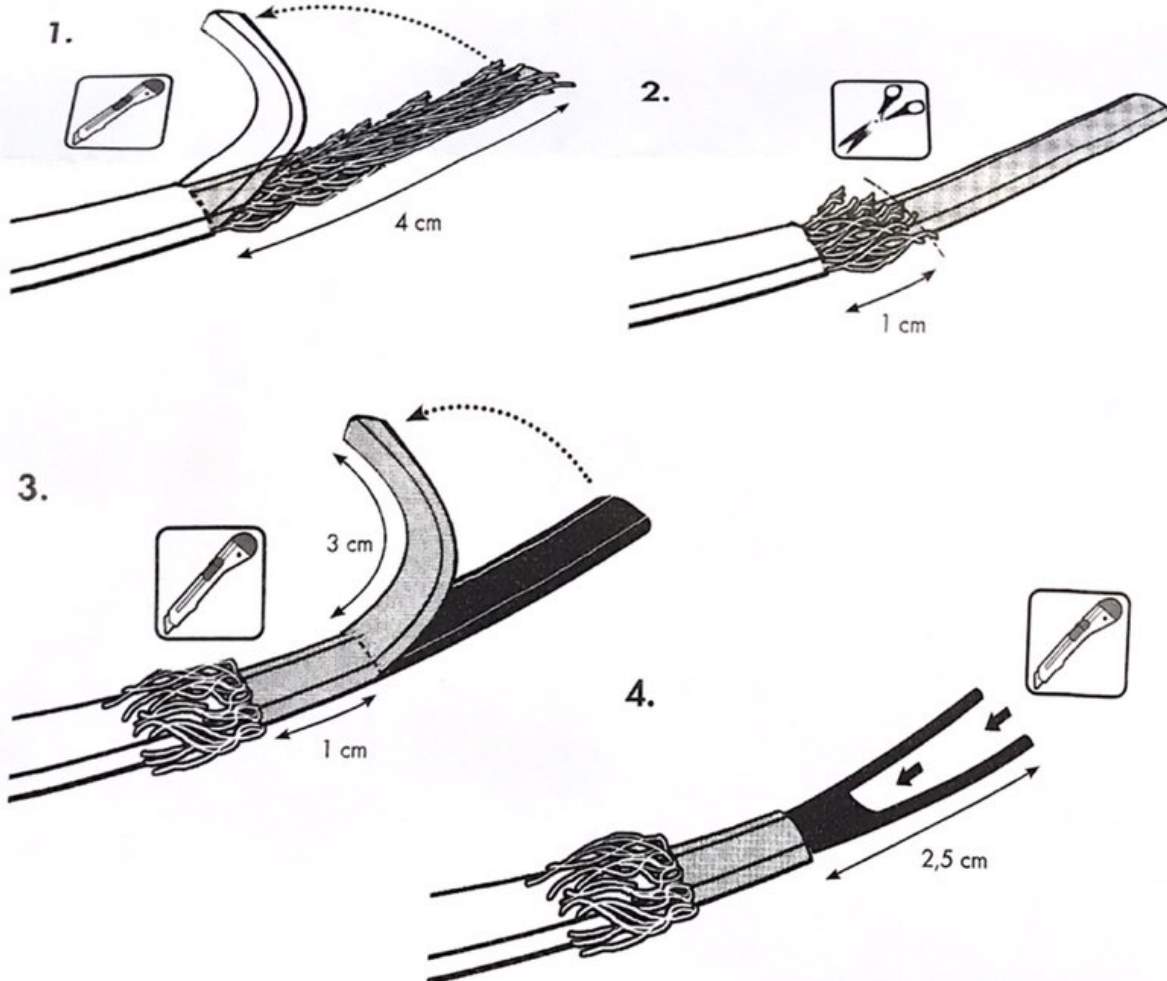

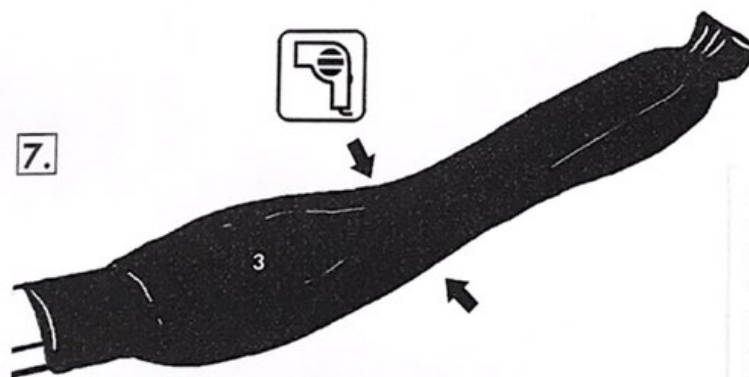
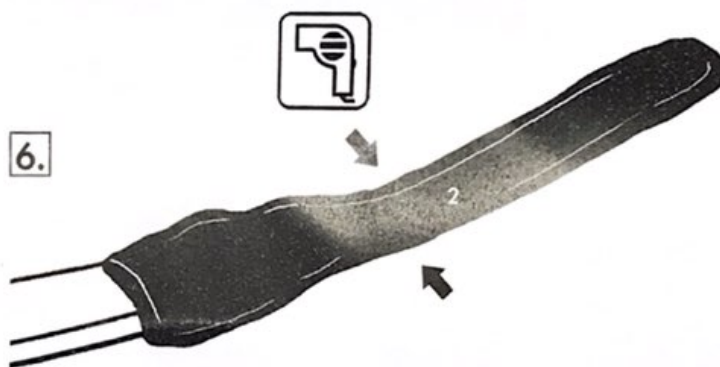
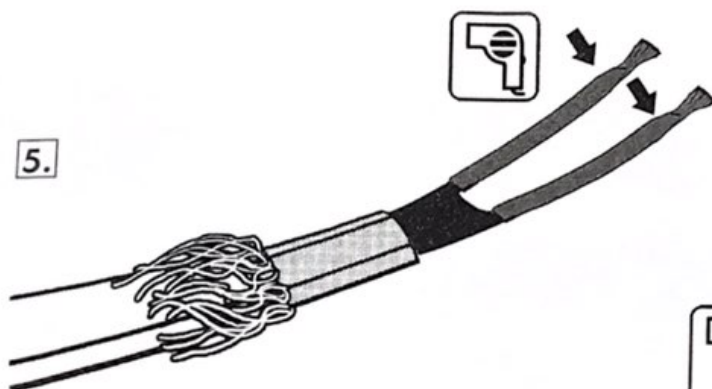

Installation nur von einem Fachmann vornehmen lassen!
The installation should be effected only by qualified appointed personnel.
L'installation doit être faite uniquement par un professionnell
De installatie moet uitsluitend door een erkent installateur uitgevoerd worden |
Instalación por persona cualificada!

Ref. 380613

T-Abzweig-Set / Kit de dérivation en T / T-Diverter Kit / T-vertakkingset / Kit de derivación en T

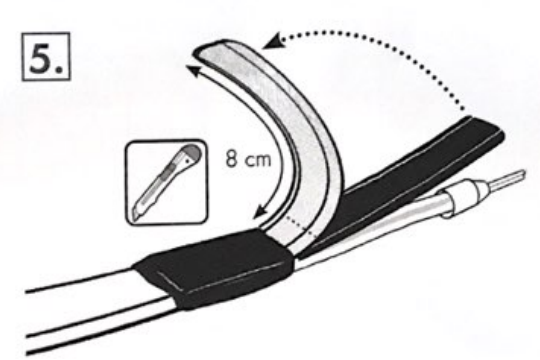
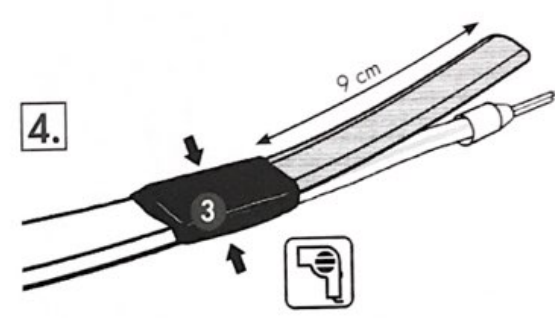
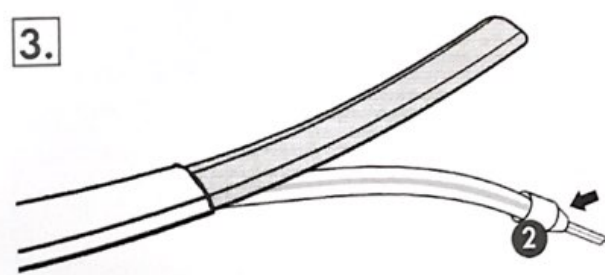
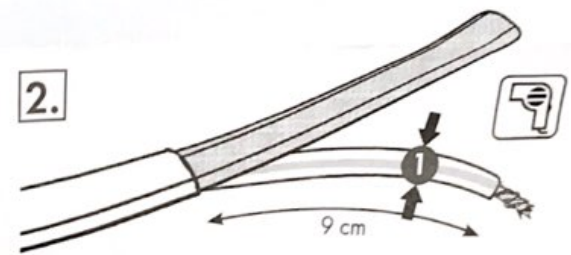
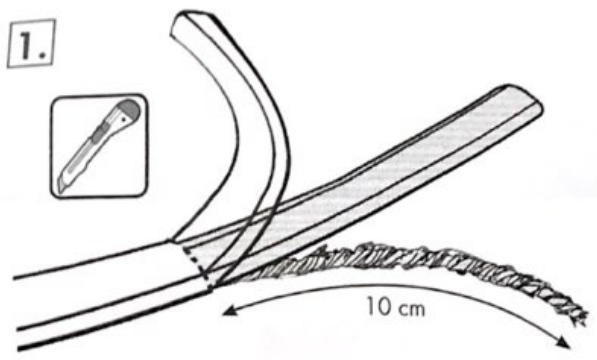

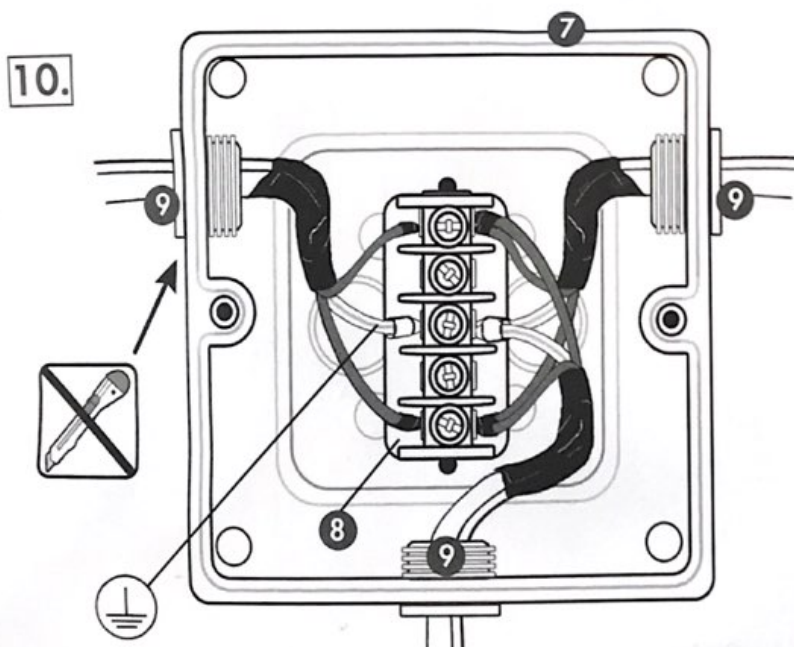
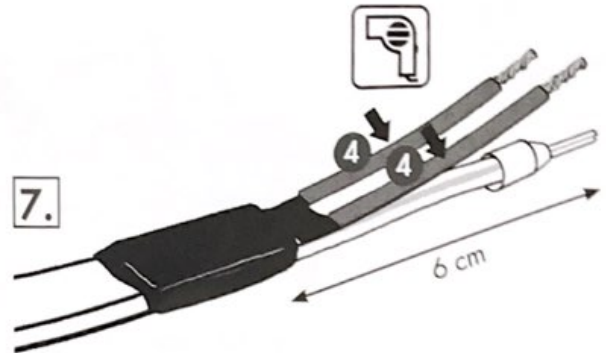
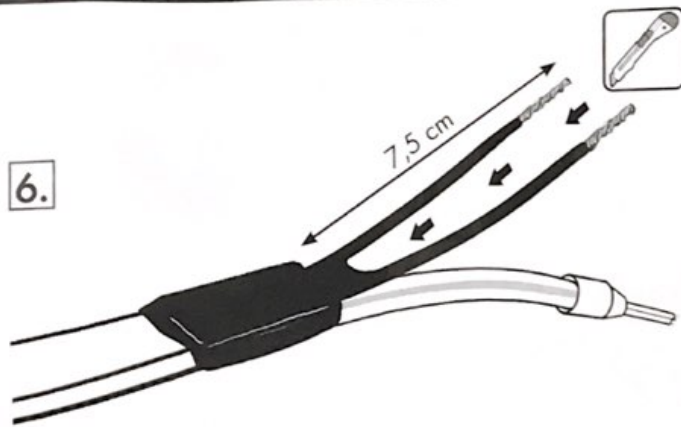

Installation nur von einem Fachmann vornehmen lassen!

The installation should be effected only by qualified appointed personnel.

L'installation doit être faite uniquement par un professionnel!

De installatie moet uitsluitend door een erkent installateur uitgevoerd worden!

¡Instalación por persona cualificada!